

LoRaWAN ESL for food retail and logistics

Alfredo Arnaud, *Senior Member, IEEE*, Martin Marioni, Mario Ortiz, Gisselle Vogel and Matías Miguez, *Member, IEEE*.

Abstract— Electronic shelf labels (ESL, or electronic price tag) are used by retailers for displaying product pricing on shelves substituting printed price tags; each ESL can display not only the price, but also text, and images, and can be remotely updated, configured, and programmed from a central server. Additionally, the emerging IoT paradigm, allows to expand the application horizon. Firstly, this work presents an analysis on how the use of Cloud-connected, intelligent, ESLs can improve food logistics in the complex scenarios of medium and large cities. Then, a low-cost ESL device, using an electronic ink (e-ink) display and the LoRaWAN protocol to communicate with the central server, aimed at price display and innovative applications in food retail and logistics, is presented. Several current consumption and communication distance measurements are shown, and the design and configuration space are explored to optimize battery life and communication reliability in the different food distribution scenarios. The proposed ESL is powered with a 500mA·h LiMnO₂ battery that can last for >8 years in a typical application, considering it communicates with a central server once per hour. The developed price tag can dynamically update the price and information for the customer, which in the case of food can be used to minimize spoilage and can easily be upgraded to incorporate sensors or smartphone interaction to develop innovative food logistics and marketing practices. Finally, a LoRaWAN time-slot allocation strategy is presented, to minimize collisions when thousand nodes are connected to a single gateway, with a minimum power consumption overhead.

Index Terms— IoT, circuits and systems for food, LoRa, e-ink.

I. INTRODUCTION

ELECTRONIC Shelf Labels (ESL, also known as electronic price-tags) that show in a small display the price, images, and other information of a product for sale in a store shelf are well known devices utilized mainly in supermarkets and small food stores, with an important growth expectation in the forthcoming years [1],[2]. The ESL devices are not intended to tag individual items but to provide in store information of a product; typically, electronic display modules are attached to the front edge of retail shelving like in Fig.1. By adopting an ESL system, retailers avoid tagging errors, printing, and labor cost, coming from regular manual tagging. Due to the difficulty of wiring hundreds or several thousand ESL in a single shop, electronic price-tags must be battery-powered devices, using wireless communication to update the information displayed. Additionally, the nodes must be of very low cost, e.g., a large

supermarket may offer thousands of different product categories requiring a different electronic label each [3]. In Fig. 2 a classic ESL system is shown, connected to a local computer inside the supermarket through a dedicated gateway; this is the most usual configuration at the present in commercial electronic price-tag systems, typically utilizing a proprietary ESL protocol for the wireless link. In the past, the first enabling technology that allowed the large-scale use of ESLs was the e-ink display [4][5] that allows to show a high-quality static image with a negligible battery power consumption, and very good resolution ranging from 100ppi to 300ppi. E-ink displays are in general monochromatic but recently some bi-color and multi-color versions have been introduced. They are relatively low-cost devices requiring an almost null static power consumption. At the present, there are dozens of wireless electronic price-tag manufacturers using e-ink displays, offering ESLs at a cost between USD 6 and USD 100 depending on the quality, size, and features of the display, generally powered by a coin or flat cell primary battery that should last for a few years. Apart from the display aesthetics, the wireless communication is the key aspect in an ESL. A survey over several available commercial price-tags was conducted during this work; most of them use a proprietary communication protocol in the ISM bands especially at 433MHz (probably because of the performance vs. cost trade-off of the transceivers in an indoors use). There are also some BLE (Bluetooth Low-Energy) enabled price-tags, and a few examples of WiFi ESLs, some wired products, and even some price-tags using a semi-passive UHF-RFID type communication so that an operator can walk the store with an RFID R/W handheld in the UHF band and update the tag information on site. The minimum components for an electronic price-tag are a low power microcontroller, an e-ink display, and a RF transceiver [6-8]. While most of the available commercial ESL systems utilize short distance, proprietary, wireless communication protocols with a local server, a new generation of Internet-connected devices is expected to emerge, which will enable new ways to work with ESLs, like distributed tag management, innovative marketing practices, sensor data logging, among others. These aspects are remarkably valuable in the case of food retail, where pricing is very dynamic, and sensor information can help to reduce spoilage. It should be noted that ESL systems market is expected to hit \$1bn by 2024 [1],[2].

In this work, firstly the advantages of electronic price tags

Alfredo Arnaud, Martin Marioni, Mario Ortiz, Gisselle Vogel, Matías Miguez are with Universidad Católica del Uruguay, Av.8 de Octubre 2738, Montevideo, CP11600, Uruguay (e-mail:mmiguez@ucu.edu.uy).



Fig. 1 An Electronic Shelf Label (ESL) is used by retailers for displaying product pricing on shelves substituting printed price tags. The product pricing is remotely updated from a central server.

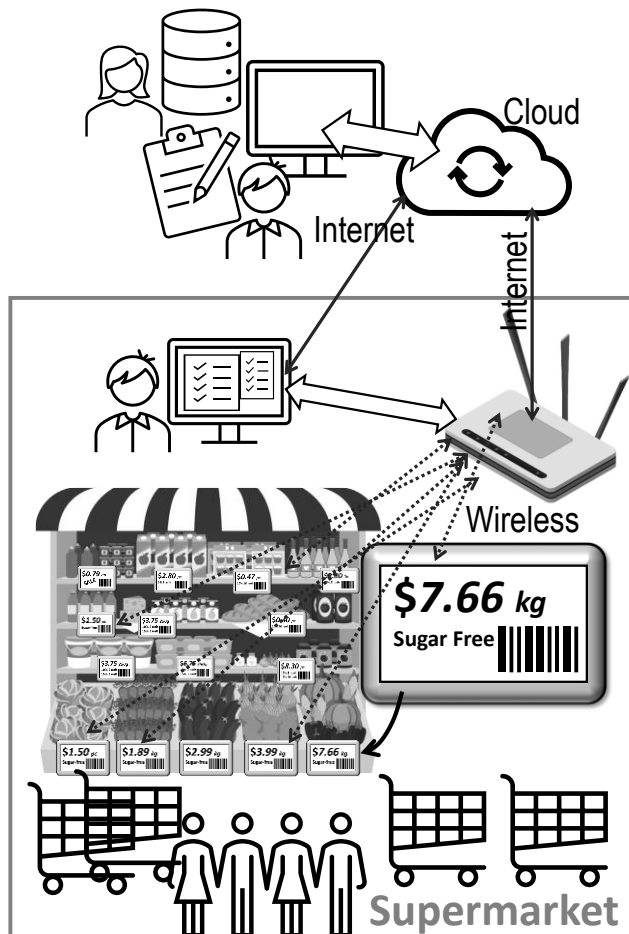

Fig. 2 An electronic price-tag (ESL) is used to dynamically label the different product categories in a store. A private wireless LAN (in most of the cases using a proprietary ESL protocol ^(*)) is used to deploy an ESL network in a supermarket or mall; ESLs are connected to a single gateway in a star topology, and the information is sent to the cloud.

^(*) LoRa WAN is proposed in this work instead.

according to the Internet of Things (IoT) paradigm are discussed, particularly in the case of food retail and logistics. As the food distribution chain becomes a complex system in modern cities, with multiple actors and business models, there is a need and an opportunity to develop also long distance, cloud-connected ESLs making the tag independent from a server in the store itself. Secondly, the development of an operative ESL prototype using a standard e-ink 2.9" display, and a LoRa transceiver for wireless communication is presented, as a proof of concept to evaluate battery life, communication distance, and network capacity, in the different ESL scenarios. Power consumption measurements, and distance communication measurements in the city of

Montevideo and in rural areas are presented. The idea of in 'the cloud' and city scale ESL networks is quite new, but most of the previous work agrees that LoRa is the best option for this specific application [8-11]. In Section II the developed prototype is described, including measurement results. Then, in Section III, power consumption is analyzed in detail, including an overview of some constrains and simulation results for timely and energy-efficient price update in markets. A simple connection scheme using a timed slot ALOHA based implementation in LoRaWAN is also presented that allows for several thousands of extra nodes to be connected to the same gateway, with a limited increase in extra messages. Finally, some conclusions are presented.

A. New options for ESL in food logistics

The second enabling technology that we consider can ramp-up the use of electronic price-tags, are the recent IoT protocols and their hardware embodiments, designed to handle hundreds or thousands of nodes with a single gateway, where each node is powered by a low-capacity battery and can transmit small payloads of reliable data up to a few kilometers away even in a noisy urban environment. These technologies include LoRa, Sigfox, RPMA, 3GPP's NB-IoT [11],[12], among others, and may help a lot in the case of food logistics. Although the main objective of an ESL is to show the price of a merchandise, in the case of food it can be very valuable to optimize the distribution chain, to prevent spoilage, etc.; updating the price every few hours can be useful [3],[10] for food products.

To begin, the two different scenarios for the ESL use we have considered must be discussed. In the first scenario, a medium or large supermarket with thousands of different products on the shelves [3] including fresh food is analyzed. In this case there is a huge number of ESLs concentrated and cluttered in a confined space (ideally one for each product category) as in Fig. 2. The chosen LAN protocol should face this situation, ideally handling thousands of nodes from a single proprietary gateway covering the large area of the supermarket or mall (10.000m² or more), avoiding collisions, and reducing the tag time-on-air to reduce power consumption. Mesh networks are avoided for the sake of power reduction. The electronic tags can be reliably updated with a minimal human intervention, displaying all relevant information while collecting, if necessary, sensors' information like the ambient temperature or the approximate consumer time looking at a product (using a micropower motion sensor). The case depicted in Fig.2 is the most common actual ESL architecture, where the electronic tags talk to a local server inside the store providing local control over update operations. If necessary, the local server is connected to the cloud like any other server, over a regular Internet connection. Classic ESLs are not long-range communication devices, providing instead a reliable link just to a reasonable store extent in the presence of obstacles and the potential interference from many sources. The second scenario is shown in Fig. 3 where several small shops in an urban environment, each one offering a few hundred product categories for sale, take advantage of an existing urban IoT network for the centralized and hourly update of prices using ESLs. In this case the IoT network does

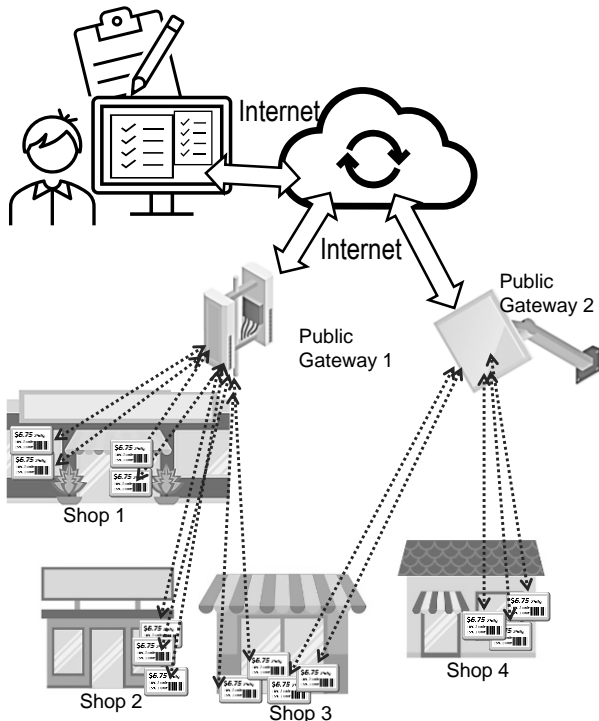

Fig. 3. The public IoT network (or a shared network) is used in a group of small shops to access electronic price-tags.

not belong to each individual store, but it is either accessed as a public service or it is owned by the group of stores. Generally, small shops have little staff and do not buy goods to resell, taking instead the merchandise on consignment. Thus, pricing information is shared by many stores for a given product category, and it is centrally updated either by the stores' administrator or by distributors leaving their products in consignment. There is not a single business model, and shops and even large supermarkets many times operate rather by renting their warehouse and shelf space to wholesalers, who must replenish merchandise and update the price-tags by themselves. In the case of small stores, they provide neither complex logistic services nor a server for third-party ESL systems or even access to a WiFi network for security reasons. The problem is even more complex with street markets, like in the city of Montevideo, that change their location daily. Long-range electronic tags operated in a city-scale network, could allow the implementation of ESL systems in heterogeneous contexts, like a distributed chain of small shops, street markets, and in the different business models for retail. In a complex multi-stakeholder context, an ESL becomes a common and auditable system for all. Permissions to access the different levels of the system can be managed in the cloud, and prices can be updated quasi-instantaneously.

A cloud-connected price-tag may allow to:

- Frequently (e.g., hourly) update the price and other information that is showed, i.e., barcodes, volume discount, etc.
- Accurately update the price along time in the case of perishable food; update the price information in semi-automatic way according to stock and demand, etc.
- Display nutritional facts and link the merchandise to a

webpage for customers' information.

- Obtain node's data and status.
 - Utilize big data and AI tools to optimize food distribution.
- Furthermore, even the lowest power modern microcontrollers have memory and computing power enough to be used for many other tasks, such as:
- Generating self QR codes for the customer to access individual product/freshness information.
 - Help with food traceability, provide a bridge with usual RFID readers[13] in retail stores.
 - Incorporate sensors, e.g., a temperature sensor to asset food safety, a gesture or presence sensor for customer interaction, a people counter as a feedback information for marketing.
 - Interact with a customer's smartphone via Bluetooth.

These characteristics are of particular importance in the case of food, as distribution can be optimized by minimizing waste, and dynamic pricing can allow the implementation of new practices that promote the circular economy concept. It should be noted that while several aspects like misplacements, maintenance, or each device onboarding, will always require some manual work, ESLs are a recognized opportunity shift from manual to automated operations in retail industry [10][21].

Ideally all the information exchange between the electronic price-tag and a main computer should occur directly or indirectly through a cloud-based service as shown in Fig. 3 and Fig.2, respectively. By having a remote price update, it is possible to optimize the demand to prevent fresh food from spoiling (e.g., lowering the price according to stock or expiration date), while allowing the implementation of innovative marketing actions.

B. An IoT technology overview and classification

The Internet of things (IoT) describes the network of physical objects —“things”— exchanging data over the Internet; IoT is an emerging topic of technical, social, and economic significance. “Things” can be autonomous cars, light bulbs, a fridge, a pet, or in this case, a price-tag; that are being combined with sensors, Internet connectivity, and powerful data analytics. At the present IoT covers so many aspects like software, hardware, big data, sensor, edge and cloud computing, AI, security and privacy, standards, and interoperability, etc., that the term ‘IoT’ is being associated to practically anything within electrical engineering. Thus, it is necessary to identify common characteristics for IoT in the case of ESLs, which include:

- Low-cost, low-power, primary battery-operated nodes, ideally lasting for years.
- Able to transmit information at a low data-rate e.g., few bytes per hour for pricing and small images to display, but not multimedia.
- Long distance e.g., 1km to 10kms operation in the case of multi-shop coverage like in Fig.3, and robust links against obstacles and interference.

Modern LP-WAN are particularly suitable for the task [6],[7],[10],[11]. A primary classification of these technologies may include the network topology (star, mesh, or tree network) and the type and frequency range of the protocol. They can be classified in three different categories:

- Free to use protocols utilizing the ISM portion of the spectrum, like LoRa[14] or Zigbee[15]. There is no fee for using these protocols once you have a transceiver, and it is possible to hire or deploy a proprietary network (gateway). Proprietary ESL protocols can be classified here.
- Licensed protocols utilizing the ISM portion of the spectrum like Sigfox[16], or RPMA[17], there is an annual fee per node for the protocol/network usage. Also, once a zone is assigned to a network it is not possible to deploy a proprietary one in the same area.
- Mobile operators' networks using an exclusive portion of the RF spectrum, like NB-IoT and 5G-NR technologies under the 3GPP[18]. In this case there is, of course, a per-node fee for the network usage, and it is almost impossible to deploy a proprietary network (only telecom companies which have access to the RF spectrum).

C. The proposed ESL system

Completely new business models are possible using ESL systems, as pointed in the previous sections, and at the present some companies are considering deploying different services over an electronic-price tag network [19][20]; but IoT-enabled ESLs are not yet a reality, probably because either the cost, power consumption issues, or the fact that networks with a massive number of battery-operated nodes still face some problems to solve. WiFi for example was initially discarded in this project because of the difficulty to connect so many nodes to a standard network (furthermore, the power consumption and coverage issues will also be reason to discard WiFi for this application).

Regarding the classification in Section I.B, in the case of a massive number of nodes, it seems only a free protocol will result a viable option as it has the lower cost; and a star-network topology to reduce the power consumption of each node. In this work the LoRaWAN [9][14] protocol was adopted as it allows allocating a large number of nodes per gateway, but in comparison with a proprietary protocol it also makes easy to implement a multi-shop network like in Fig. 3. While LoRa is particularly suitable for battery operated devices and has been vastly employed in IoT applications, the interest in LoRa price-tags is recent with almost no practical examples[8-10],[27].

In this work, the development of an operative ESL prototype using a standard e-ink 2.9" display, and a LoRa transceiver for wireless communication is presented. In the next section the developed prototype is described including measurement results. Then power consumption is analyzed in detail, including an overview of some constrains and simulation results for timely and energy-efficient price update in stores and markets.

II. ELECTRONIC PRICE-TAG PROTOTYPE

A block diagram of the developed price-tag is shown in Fig. 4. For the e-ink display, a 2.9 inch, 112 ppi display [22] was selected, that can be seen from 1-2 meters and with enough resolution to permit a QR code to be displayed and properly scanned with a smartphone. The display is monochrome with a resolution of 296×192 pixels and a deep sleep consumption of

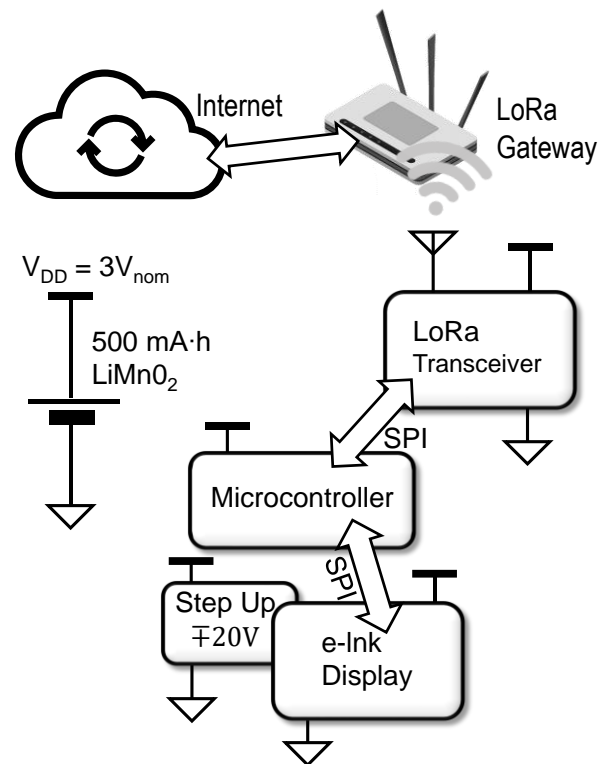

Fig. 4. A block diagram of the developed ESL.

just 1 μ A. An 8 bits, low power microcontroller was selected [23], with a large program memory of 128kB Flash for the storage of images and remote firmware update if necessary and ~4kB SRAM; the MCU has a very low sleep current consumption of 350nA including a real time clock (RTC) @1.8V V_{DD} . A SX1278 [24] LoRa transceiver operating in the 433 MHz band (433.92 MHz center frequency), coupled with a 433Mhz helical antenna was utilized to provide RF communication. Finally, to power the device a 3V, 500mAh LiMnO₂ battery was selected, as these batteries are better fitted for the high current pulses required by the LoRa module (up to 100mA) during transmission (TX). A 100 μ F tank capacitor is placed in parallel with the battery to filter noise, but a simple calculation shows that it hardly helps in the case of TX supply current spikes. A DC-DC converter is required to generate $\pm 20V$ supply necessary for the display module only during its refresh. The DC-DC controller is included in the display module, requiring only additional capacitors, inductor, and pass-transistors. To house the system, the custom 91×48×12mm 3D printed case shown in Fig. 5 was designed. The developed price-tag is shown in Fig. 6. The estimated cost of the node is less than USD 10 each, fabricated in 1000 units batches which is in accordance with the application needs.

A. LoRa basics and core firmware description

Although it is not the intention of this work to review the LoRa protocol since there is a lot of public information about it [25][26], it is necessary to at least mention the basic parameters used to configure the link. Firstly, LoRaWAN defines three modes (Classes) to cater for different situations in terms of

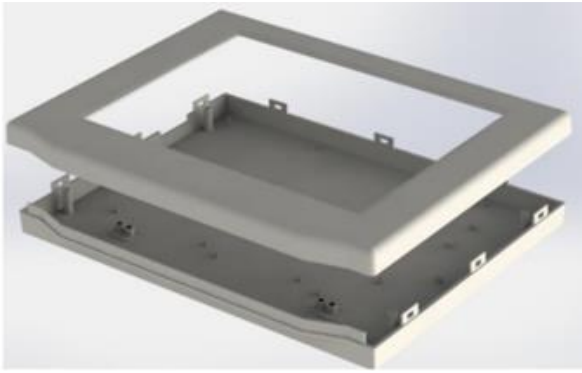

Fig. 5 A render of the designed plastic case.



Fig. 6 The fabricated LoRa ESL prototype.

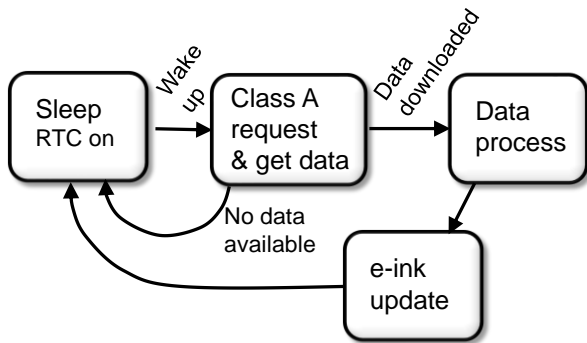

Fig. 7 E-Tag main firmware diagram block.

update rate and power consumption. Class A is supposed to consume the least power; in this case the node always starts the communication event (transmits an ID or service request packet, TX) and waits for an acknowledgement (Ack) and downlinks data at certain time RX slots after TX. Class B instead, provides additional downlink windows, and according to [27] is a promising option to save power with bounded latency. In Class C, the node is waiting for data most of the time thus has no major interest in steady state, in the case of a low

power ESLs, but can be utilized in some conditions e.g., in the case of firmware update. Apart of the network access type, also the Spread Factor (SF), Bandwidth (BW), Code Rate (CR), and transmit power TX_p should be configured,

According to Fig. 2, and Fig. 3, there are two main cases which can be distinguished in food distribution and retail. In the first case, up to a few thousand ESLs are highly concentrated in a supermarket transmitting to a single gateway, while in the second case, several small shops are distributed along the city, where it is more likely to find repeated products (e.g., the same fresh food) in several shops, transmitting to a farther and not necessarily known gateway. The optimum configuration is not necessarily the same for both cases, which will be discussed in Section III.

Many different configurations, prototypes, and communication strategies were tested during this work, but an initial firmware was developed configuring the transceiver in Class A for the sake of power consumption reduction, a simple state diagram is shown in Fig. 7. The node remains in sleep most of the time. Periodically (e.g., once an hour) it wakes up, synchronizes, send a status report, and checks for new data from the server, perform other tasks and updates the e-ink display, if necessary, before entering sleep mode again.

Because of the impact of the data amount in bytes to transmit, in the time on air and power consumption, standard interoperability formats like JSON or XML should be avoided. There is a lack of a standard for ESLs thus a proprietary binary format was chosen for test purposes. A few fixed length messages were defined including:

- An 8Bytes payload message for node TX (with node ID, status report, groups and request type information for future use). A simple built-in self-test routine was implemented to at least check battery condition and configuration data thus warnings bits are included in the status report.
 - A 32Bytes payload data download (RX from the node-side) message including price and a short ASCII text for basic display update. Serves as an Ack as well.
 - A simpler 2Bytes payload RX acknowledgement (Ack) message.
 - A 1.2kBytes RX uncompressed image message, for a small graphic image to display next to the price.
- More complex message structures can also be developed in the future.

The data is always encrypted using AES128 and an over the air activation (OTAA) method was implemented for onboarding new nodes to the network. Finally, a custom firmware over the air (FOTA) protocol for updating the firmware was also designed and tested.

B. Measurement results

Several communication distance, and power consumption measurements were obtained, with prototype nodes either transmitting between them point-to-point, or against a dedicated gateway (LoRaWAN). In the former case a fixed node was left on the first floor of a small building in Montevideo (a 1.5million people city with moderate height buildings), and a second mobile node was transmitting every 10

seconds and then waits for an Ack packet, the fixed node using a ¼ wave stick antenna, the mobile node using a helical antenna. Data packets began to be lost at 1km and a reliable communication was possible up to 1.5kms ... 2kms depending on the direction. The same test was repeated with the fixed node over a window on the 25th floor of one of the tallest buildings in the city. In this case the communication was possible up to 7kms ... 11kms depending on the direction. Finally, the node-to-node connection was tested to work correctly at a range of >13kms in a farm, with the fixed node at approximately 3mts height. A gateway was implemented using a RAK831 module [28] and a Cisco 4G-LTE-ANTM-D antenna [29] and was placed 10mts above ground for LoRaWAN range measurements. The system was working correctly at measured distances of more than 8km (within the city but in direct antenna view). Finally, 4 nodes were left near a lone gateway to transmit every 10 seconds during a 24-hour period, and just 3 messages from the nodes to the gateway were lost, while no message from the gateway to the nodes was lost. LoRaWAN devices were also tested with the gateway in a 1st floor in the city, in this case the communication distance strongly depends on the direction from 400mts to 2kms for a reliable link. In the LoRaWAN measurements, the nodes were configured @ $SF=7$, $TX_p=13\text{dBm}$, $BW=125\text{kHz}$; in the former point-to-point measurements $SF=12$, $TX_p=20\text{dBm}$ to increase the link distance.

Power consumption measurements were performed to confirm the estimated battery duration, and to later set the communication strategy. The experimental setup is shown in Fig. 8, the ESL under test (DUT) is connected to the battery through a series resistor R, the switch SW in parallel is placed to avoid a brown out reset (BOR) in the case of current spikes out of the measurement period and large R values (as necessary to measure low currents), the tank capacitor C is used to filter current spikes. A custom instrumentation amplifier using three precision opamps is used to sense the current through R and measured at the output either using an oscilloscope or a true rms voltmeter. Measured average battery consumption $\langle I_{Bat} \rangle$ values

are shown in Table I. A detailed discussion of power consumption issues will be presented in the next section. In Table I, the estimated values are typical values from datasheets, but the measured values were used for the later power estimations, except for the transceiver sleep current. The problem with this measurement is the power consumption of a RF switch in the transceiver module that consumes static current and should be substituted in a future version of the ESL.

In a first approach, for an hourly update of the price-tag, the estimated total average supply current $\langle I_{Bat} \rangle$ can be calculated using:

$$\langle I_{Bat} \rangle = \frac{I_{TX} \cdot t_{TX} + I_{RX} \cdot t_{RX} + I_{dis} \cdot t_{dis} + I_p \cdot t_p}{(24 / N) \cdot 3600} + I_{Sleep} \quad (1)$$

where I_{TX} , I_{RX} , I_{dis} , t_{TX} , t_{RX} , t_{dis} , are the TX, RX, and display update current consumption and time in seconds, respectively.

TABLE I. MEASURED CURRENT CONSUMPTION

Device	Condition	Estimated	Measured
	e-ink display	Deep Sleep	1 μA
Display update ^(a)		3 mA	3.5 mA
LoRa transceiver	TX ^(b)	29 mA	20.5 mA
	TX ^(c)	100 mA	89 mA
	RX	10.8 mA	10.8 mA
	Sleep	0.1 μA	4 μA ^(d)
MCU	Sleep	1 μA	1.1 μA
	Run @32.768kHz	8 μA	8.5 μA
	Run @8MHz	0.95mA	1.2mA

^(a) Includes the DC-DC

^(b) $TX_p=13\text{dBm}$.

^(c) $TX_p=20\text{dBm}$.

^(d) This value was discarded for power estimations.

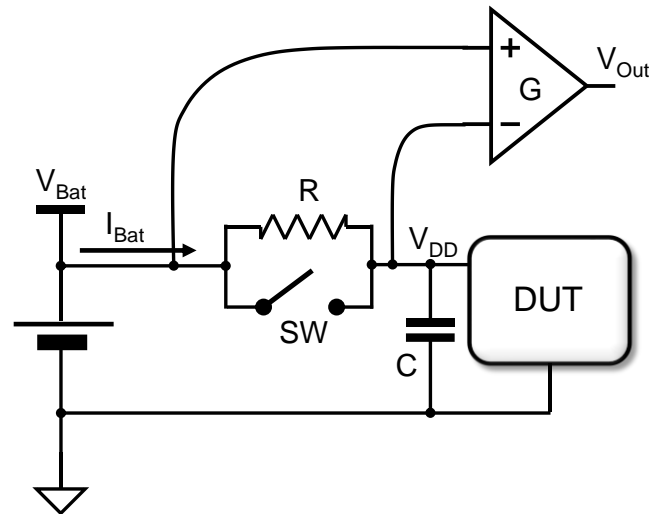

Fig. 8. Experimental setup for current consumption measurements.

I_p , t_p , are the MCU processing current consumption and time for a single TX-RX cycle and display update if necessary; $t_d = t_{TX} + t_{RX} + t_{dis}$ is assumed, but an extra t_p time should be considered in the case of sensor data processing or any other compute-demanding task in future versions of the ESL. Current consumptions I_j are obtained from Table I, I_p is that of the MCU@8MHz. I_{Sleep} is the sum of the MCU, LoRa, and display's sleep currents, for the LoRa module a more realistic $1\mu\text{A}$ value was considered. TX and RX time on air are calculated using a standard LoRa calculator with values resulting very close to measured times. An average $t_{dis}=1\text{s}$ time was measured for the full display update, including DC/DC setup time that was measured $<20\text{ms}$. According to (1) $\langle I_{Bat} \rangle = 4.8\mu\text{A}$ corresponding to almost 12yrs ESL operation. This estimation uses LoRa in Class A, $SF=7$, $BW=125\text{kHz}$, $CR=5/4$ parameters, assumes an 8Bytes node TX@13dBm request message for ID, and 32bytes RX download data back from the gateway for price update (no graphic image).

III. CURRENT CONSUMPTION ANALYSIS, AND ESL OPERATION STRATEGY.

The current consumption sources can be individualized for a design space exploration, to set an optimum ESL operation strategy. According to the communication distance measurements and former battery life estimation, operating LoRa in Class A, $SF=7$, $BW=125\text{kHz}$ is a good starting point. Using these parameters, in Fig. 9 the normalized current consumption contribution of TX (ESL sync/service request), RX (Ack+data download), Update (display update + MCU data processing), and Sleep (Display + LoRa module + MCU) are shown for an hourly rate price-tag communication. The information is presented for: A, the price-tag starts the communication with an 8Bytes ID message (which includes a status report, i.e. known failures and low battery indicator) and just receives a 2Bytes Ack message; B, the price-tag receives 32Bytes display update information; C - the price-tag receives 32Bytes update information plus a 1.2kByte image for the display. The result is an acceptable battery life in all cases; although a frequent image update may seem unnecessary, image update can be used for innovative marketing actions, etc. There are two issues still to solve, firstly, the total time on air in the case of the frequent update of a very large number of nodes should be examined (but it does not seem to be a problem in the case of food, because only a small fraction of the tags in a supermarket or shop will frequently update the display). But also, in the case of Fig. 3, it might be necessary to communicate the price-tag to a farther gateway thus the SF shall be increased as well [30][31]. To evaluate the impact of the SF in the battery life, the normalized current consumption contribution of each block is presented in Fig. 10 while varying the SF for the case B in Fig. 9 (8Bytes TX message +32Bytes RX data download). Note the battery life reduction is significant but still acceptable for the larger SF s but a frequent update of the graphic image of the display may not be possible if requires in this case also an unacceptable time on air. Battery life results in Fig.9-C are very similar to those in [7], the closest reference to compare with for an ESL with a similar battery utilizing an 802.15.4 radio, but in our case the ESL is a long-range device.

Finally, when considering a scenario where several thousands of nodes could be connected to the same gateway e.g., inside the supermarket in Fig. 2, the scalability of the network must be analyzed to determine its viability [34]. In [32,33] a simulator (LoraSim) for studying the scalability of LoRa is presented. Simulations show that if all nodes are set to the same configuration ($SF=7$, $BW=125\text{kHz}$) the amount of collision increases with the number of nodes, as shown in Fig. 11, where each point in this plot is the average of 5 different 3 hours simulations; N nodes were used, each sending a message every 1 hour. For more than a couple of thousands of nodes, the number of collisions per hour make it impractical for the target application. Nevertheless, two possible solutions for increasing the number of nodes were evaluated using simulations. Firstly, it is possible to allow the node configuration to be determined by the gateway as proposed in [33], depending on its distance from the gateway and to reduce the chance of a collision. In this

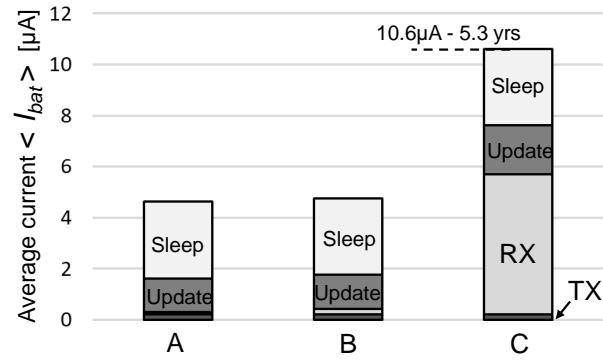

Fig. 9 Normalized (average) current consumption sources for a price-tag communicating and updating the display once an hour: A – only an Ack is received, B – 32Bytes update info is received, C - 32Bytes+1.2kByte graphic image update info is received. $SF = 7$, $BW = 125\text{kHz}$, $\text{TX}@13\text{dBm}$, Class A node. Note the battery life is >5yrs even in the case of a frequent image update in this configuration.

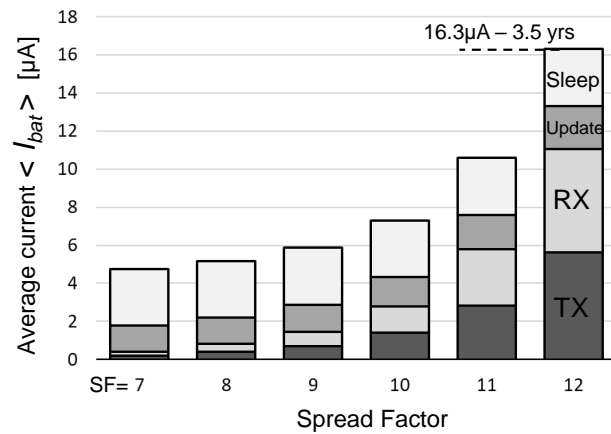

Fig. 10 Normalized (average) current consumption sources while varying the SF, for a price-tag that communicates and updates the display once an hour, transmitting 2Bytes ID message, and receiving 32Bytes update info. $BW = 125\text{kHz}$, $\text{TX}@13\text{dBm}$, Class A node. Note the battery life falls to 3.5yrs in the case of $SF=12$.

simulation all the nodes tried several different configurations (changing the SF mainly) before selecting the one that reduced the chance of collision. As seen in Fig. 12, the number of lost packets because of collisions is significantly reduced, and the number of nodes that can simultaneously operate therefore more than doubles. But this solution is limited, as using different configurations (particularly changing the SF) directly impacts the current consumption of the nodes (as depicted in Fig. 10).

A second solution is proposed in this work, that maintains all the nodes with the same configuration while allowing each node to dynamically change the instant it starts a communication. The main idea is that each node communicates initially when it is turned on, and then does not communicate until for example one hour later (calculated using its internal RTC). The proposed method for self-configuration, consist in allowing the node that tries to contact the gateway and cannot communicate, to wait a random time (between 5 and 720 seconds in our simulations) before trying to communicate again. If it is successful, it will

not try to communicate again until exactly one hour later. Using this strategy each node finds a free “time slot” after successive trials, where it can communicate avoiding collisions. In Fig. 13, the number of collisions after each hour of operation using this technique, is shown for different numbers of nodes, all working with the same configuration ($SF=7$, $f=125\text{kHz}$, time on air $\sim 100\text{ms}$). The number of collisions is reduced every hour, as expected, indicating that the nodes configure themselves in different time slots. In this simulation the time was discretized in 100ms steps, and a collision was assumed if two different nodes try to transmit in the same step or in consecutive steps. For each simulation, the average of at least 5 runs is presented. As the nodes are not synchronized, small changes in the time count for the next wake-up may cause collisions if the system continues operating for several hours/days, but the system can generate minimal extra synchronization messages itself to avoid this problem, or it can keep running with the same initial method of self-configuration. Table II shows the number of extra messages required for this initial configuration per node, showing the energy cost is minimal in the long run, but that it increases as the number of nodes also increases. The two analyzed solutions (that in [33] and the proposed self-configuration method), both indicate that several thousand nodes can be used connected to a single gateway once an hour while using Class A LoRa protocol. The proposed solution can maintain a reduced consumption of the nodes, by changing the moment the communication happens instead of the configuration (the SF in particular) which increases power consumption. The result is similar to other approaches as presented in [35, 36], which show similar results for other applications. The proposed solution will not work for an unlimited number nodes as the “time slots” become saturated, so if a larger number of nodes is required a bulk synchronization like suggested in [27] using Class B nodes can also be implemented, which can be beneficial for the case of several small shops, as there are probably several different nodes which show the same price/picture.

Summarizing, for food and retail applications, according to our measurement results and Fig. 10, a $SF=7$ to 9 is an adequate initial option and operating a large number of nodes in LoRa Class A as necessary in a supermarket is possible. A realistic average consumption of $7\mu\text{A}$ corresponding to 8yrs battery life was estimated for this case $SF=9$, $BW=125\text{kHz}$, $TX_p=13\text{dBm}$, assuming 16 ESL communication instances a day, only 8 display updates, 1 image update a day, and 2 firmware updates per year. Transmit power can be increased up to 20dBm with a small power consumption overhead, the main problem being the instant battery voltage drop because of the large current spikes during TX. LiMnO_2 batteries are adequate for 100mA spikes but a much cheaper e.g., CR2450 battery can be safely employed if the transmit power is set to 13dBm at a maximum.

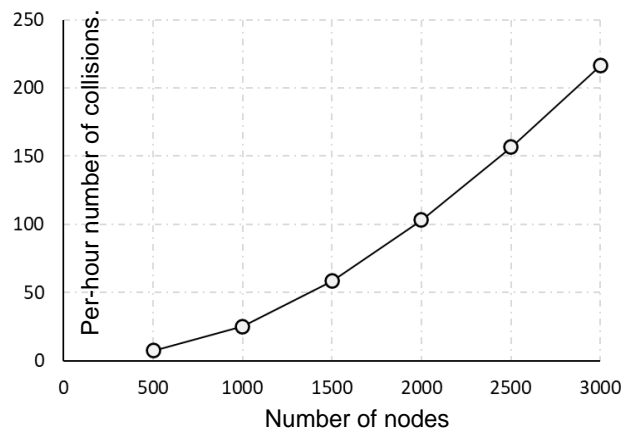

Fig. 11 Simulated collision per hour for different number of nodes connected to a single gateway. All nodes are set to the same configuration ($SF=7$, $BW=125\text{kHz}$), and the average of 5 runs is presented.

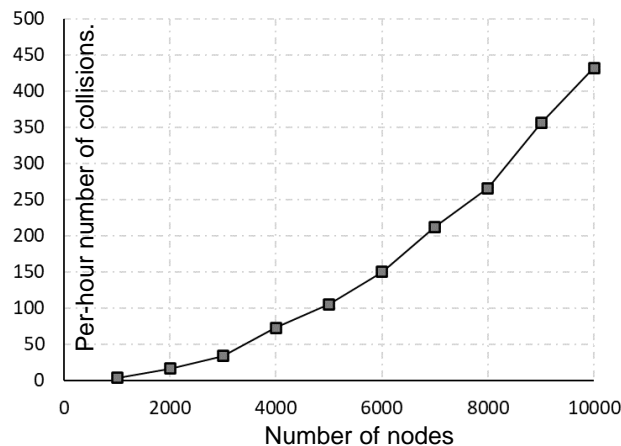

Fig. 12 Simulated collision per hour for different number of nodes connected to a single gateway. Each node configuration is selected by the gateway to reduce collisions. The average of 5 simulation runs is presented.

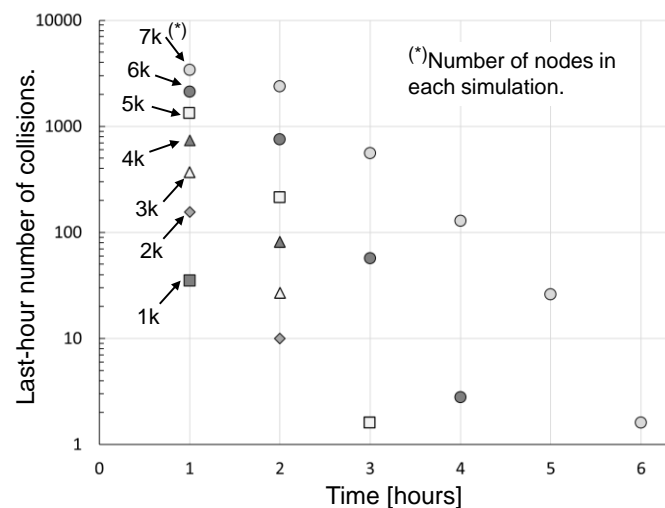

Fig. 13 Simulated number of collisions in each hour before the system reaches equilibrium for different number of nodes (in logarithmic scale), using the proposed self time-slot allocation once a collision is assumed.

TABLE II. SELF-CONFIGURATION FOR DIFFERENT NUMBER OF NODES

Number of nodes	Number of Extra messages per node before reaching equilibrium	
	Number of hours before the system reaches equilibrium	Number of Extra messages per node before reaching equilibrium
1000	1	0.036
2000	2	0.083
3000	2	0.132
4000	2	0.204
5000	3	0.309
6000	4	0.488
7000	6	0.928

IV. CONCLUSIONS

In this work the challenges for food logistics and retail in modern urban environments were introduced, as well as a discussion on how the use of Cloud-connected, intelligent, ESLs can improve food logistics in these complex scenarios. Then, an IoT based Electronic Shelf Label (ESL or electronic price-tag) was presented. The device is aimed at price display, and as a platform to develop innovative traceability, logistic, and marketing actions in the food distribution chain. Each price-tag can display the item's price, a text with information for the customer, and images, and can be remotely updated, configured, and programmed. LoRaWAN technology was selected to cloud-connect the price-tags, an option that is yet underexplored for this specific application.

A LoRa Spread Factor $SF=7$, bandwidth $BW=125\text{kHz}$, and $Tx_p=13\text{dBm}$ transmit power shown to be a good option for a highly concentrated number of ESLs relatively close to a gateway (supermarket case) in an urban setting, but also long transmission urban distances were achieved in the same configuration as necessary for the case of multiple distributed small shops sharing merchandise options. Several current consumption measurements estimations were presented, and the design space was explored to optimize battery life and communication reliability, as necessary in a realistic food distribution and commercialization chain. The price-tag is powered with a $500\text{mA}\cdot\text{h}$ LiMnO_2 battery lasting more than 8 years in a typical application, it was measured to work up to 8 km in an urban environment and has a cost of less than USD 10.

The scalability of the network for several thousands of nodes was analyzed through simulations, including a proposed simple self-configuration mechanism, to minimize collisions when thousand nodes are connected to a single gateway, with a minimum power consumption overhead.

A problem that ESL systems still face, is the lack of a standard for data interoperability. In this case a proprietary, compact, binary format was implemented. But it is to be expected that specific compact standards will emerge in the forthcoming years for the information exchange and command of ESLs.

The developed price tag can be used to update the price and information displayed through the Web, allowing the customer

to get more information about the product is buying. In the case of food, a proper use of the ESL may help to reduce spoilage, and distributions costs. The price-tag also can be upgraded in the future to incorporate sensors or smart phone interaction to develop innovative food logistics and marketing practices.

REFERENCES

- [1] Technavio, "Electronic Shelf Label Market to garner USD 1.08 Billion with almost 21% CAGR during 2021-2025" [Online]. Available: <https://www.prnewswire.com/news-releases/electronic-shelf-label-market-to-garner-usd-1-08-billion-with-almost-21-cagr-during-2021-2025-technavio-301255574.html>, [Accessed 29-May-2021].
- [2] Intrado, "Electronic Shelf Label (ESL) Market to hit \$1bn by 2024: Global Market Insights, Inc." [Online]. Available: <https://www.globenewswire.com/news-release/2018/09/18/1572161/0/en/Electronic-Shelf-Label-ESL-Market-to-hit-1bn-by-2024-Global-Market-Insights-Inc.html>, [Accessed 29-May-2021].
- [3] M. Garausa, E. Wolfstein, U. Wagner, "Shoppers' acceptance and perceptions of electronic shelf labels", *Journal of Business Research*, vol. 69-9, pp. 3687-3692, 2016.
- [4] U. Primožic, "Electronic paper explained: what is it and how does it work?" [Online]. Available: <https://www.visionect.com/blog/electronic-paper-explained-what-is-it-and-how-does-it-work/> [Accessed 29-May-2021].
- [5] J. L. Zalesky and A. Wakefield, "Integrating segmented electronic paper displays into consumer electronic devices," *2011 IEEE International Conference on Consumer Electronics (ICCE)*, pp. 531-532, 2011.
- [6] Taewon Suh et al. "Electronic Shelf Labels: Prototype Development and Validation Using A Design Science Approach", *Journal of Information Technology Management*, vol. 29-4, pp. 24-38, 2018.
- [7] J. Ock, H. Kim, H. Kim, J. Paek and S. Bahk, "Low-Power Wireless With Denseness: The Case of an Electronic Shelf Labeling System—Design and Experience," *IEEE Access*, vol. 7, pp. 163887-163897, 2019.
- [8] M. Miguez, M. Marioni, M. Ortiz, G. Vogel and A. Arnaud, "An IoT-based electronic price-tag for food retail," *26th IEEE International Conference on Electronics, Circuits and Systems (ICECS)*, pp. 189-192, 2019.
- [9] M.A.A. Khan; X. Lian; I. Khan Mirani; L. Tan, "Research on Key Technologies of Electronic Shelf Labels Based on LoRa", *Journal on Big Data*, 2021. doi:10.32604/jbd.2021.016213
- [10] H.-S. Kim, H. Cho, M.-S. Lee, J. Paek, J. Ko, and S. Bahk, "Marketnet: An asymmetric transmission power-based wireless system for managing e-price tags in markets," *Procs. of the 13th ACM Conference on Embedded Networked Sensor Systems*, pp.281–294, 2015.
- [11] F. S. Dantas Silva et al., "A Survey on Long-Range Wide-Area Network Technology Optimizations," *IEEE Access*, 2021. doi: 10.1109/ACCESS.2021.3079095.
- [12] Q. M. Quadir, T. A. Rashid, N. K. Al-Salihi, B. Ismael, A. A. Kist, and Z. Zhang, "Low power wide area networks: A survey of enabling technologies, applications and interoperability needs," *IEEE Access*, vol. 6, pp. 77454–77473, 2018.
- [13] A. Arnaud and G. Costa, "Ultra low-cost sensors using RFID standards for data collection, for IoT systems in food production and logistics," *2020 IEEE 11th Latin American Symposium on Circuits & Systems (LASCAS)*, 2020.
- [14] LoRa Alliance documents [Online]. Available: <https://lora-alliance.org/>, [Accessed 23-Feb-2021]
- [15] Zigbee Alliance [Online]. Available: <https://zigbeealliance.org/solution/zigbee/>, [Accessed 23-Feb-2021]
- [16] A. Lavric, A. I. Petrariu and V. Popa, "Long Range SigFox Communication Protocol Scalability Analysis Under Large-Scale, High-Density Conditions," *IEEE Access*, vol.7, pp.35816-35825, 2019.
- [17] *Random Phase Multiple Access*. Accessed: Mar. 28, 2018. [Online]. Available: <https://www.ingenu.com/technology/rpma> [Accessed 23-Feb-2021]
- [18] 3GPP documents [Online]. Available: <https://www.3gpp.org>, [Accessed 23-Feb-2021]

- [19] Imagotag products, services, infrastructure, [Online]. Available: <https://www.ses-imagotag.com/en/infrastructure/>, [Accessed 23-Feb-2021]
- [20] Huawei Electronic Shelf Label products and services [Online]. Available: <https://e.huawei.com/en/solutions/industries/retail/digital-store/electronic-shelf-label>, [Accessed 23-Feb-2021]
- [21] Electronic Shelf Label Market [Online]. Available: <https://www.marketsandmarkets.com/Market-Reports/electronic-shelf-label-market-40815676.html> [Accessed 17-Jul-2021].
- [22] DKE DEPG-0290 display information [Online]. Available: <http://www.china-epaper.com>. [Accessed 19-Feb-2021]
- [23] Microchip PIC18F47K40 info and datasheet [Online]. Available: <https://www.microchip.com/wwwproducts/en/PIC18F47K40>. [Accessed 23-Feb-2021]
- [24] SX1278 transceiver information and datasheet [Online]. Available: <https://www.semtech.com/products/wireless-rf/lora-transceivers/sx1278> [Accessed 23-Feb-2021].
- [25] LoRa developers' information and forum [Online]. Available: <https://lora-developers.semtech.com/>. [Accessed 23-Feb-2021].
- [26] J. P. Shanmuga Sundaram, W. Du and Z. Zhao, "A Survey on LoRa Networking: Research Problems, Current Solutions, and Open Issues" *IEEE Communications Surveys & Tutorials*, vol. 22-1, pp. 371-388, 2020.
- [27] Y. Wang, G. Chen, J. Bu and W. Dong, "MoRa: A LoRa-Based System for Timely and Energy-Efficient e-Price Tag Update in Markets," *2019 IEEE 25th International Conference on Parallel and Distributed Systems (ICPADS)*, pp. 671-678, 2019.
- [28] RAK831 concentrator module [Online]. Available: <https://www.rakwireless.com/en/WisKeyOSH/RAK831> [Accessed 23-Feb-2021]
- [29] Cisco 4G-LTE-ANTM-D antenna information [Online]. Available: https://www.cisco.com/c/en/us/td/docs/routers/access/wireless/hardware/notes/4G3G_ant.html [Accessed 23-Feb-2021]
- [30] S. Sağır, İ. Kaya, C. Şişman, Y. Baltacı and S. Ünal, "Evaluation of Low-Power Long Distance Radio Communication in Urban Areas: LoRa and Impact of Spreading Factor," *2019 Seventh International Conference on Digital Information Processing and Communications (ICDIPC)*, pp. 68-71, 2019.
- [31] A. Waret, M. Kaneko, A. Guitton and N. El Rachkidy, "LoRa Throughput Analysis with Imperfect Spreading Factor Orthogonality," *IEEE Wireless Communications Letters*, vol.8-2, pp. 408-411, 2019.
- [32] M. Bor, U. Roedig, T. Voigt, J. Alonso, "Do LoRa low-power wide-area networks scale?". *MSWiM '16 Proceedings of the 19th ACM International Conference on Modeling, Analysis and Simulation of Wireless and Mobile Systems*, pp. 59-67, 2016.
- [33] T. Voigt, M. Bor, U. Roedig, J. Alonso, "Mitigating Inter-Network Interference in LoRa Networks", *EWSN '17 Proceedings of the 2017 International Conference on Embedded Wireless Systems and Networks*, pp. 323-328, 2017.
- [34] F. Silva, et al. "A Survey on Long-Range Wide-Area Network Technology Optimizations," *IEEE Access*. PP. 10.1109/ACCESS.2021.3079095.
- [35] G. Yapar, T. Tugcu and O. Ermis, "Time-Slotted ALOHA-based LoRaWAN Scheduling with Aggregated Acknowledgement Approach," *2019 25th Conference of Open Innovations Association (FRUCT)*, 2019, pp. 383-390
- [36] D. Zorbas, C. Caillouet, K. Abdelfadeel Hassan, and D. Pesch, "Optimal Data Collection Time in LoRa Networks—A Time-Slotted Approach," *Sensors*, vol. 21, no. 4, p. 1193, Feb. 2021.



Alfredo Arnaud (M'97-SM'11) is with the Department of Engineering, Universidad Católica, Montevideo-Uruguay. He received the M.S. and Ph.D. degree in electronics from the Universidad de la República, in 2000, and 2004. Since 1997 he was involved in several research and industrial projects in the field of CMOS analog design, medical and industrial electronics, RFID and IoT. His current research interests include high-performance circuits for implantable medical devices and analog signal processing, and the development of RFID and IoT innovative devices for the agribusiness sector.



Martin Marioni, received his Graduate degree in Electronics Engineering from the Universidad Católica, Montevideo Uruguay in 2017. Since 2019 he has been working in Pensur, Uruguay.



Mario Ortiz, received his Graduate degree in Electronics Engineering from the Universidad Católica, Montevideo Uruguay in 2017. Since 2018 he has been working in Huawei, Uruguay.



Gisselle Vogel, received his Graduate degree in Electronics Engineering from the Universidad Católica, Montevideo Uruguay in 2017. Since 2019 he has been working in Andritz, Uruguay.



Matías R. Miguez (M'06), received his PhD degree in 2017 from Universidad Nacional del Sur, Bahía Blanca, Argentina MSc and Graduate degree in Electronics Engineering from the Universidad Católica, Montevideo Uruguay in 2008 and 2005 respectively. He has also received a Graduate degree in Physics from the Universidad de la República, also in Montevideo, Uruguay in 2007. In 2005, he joined the Electrical Engineering Department, Universidad Católica, Montevideo, Uruguay. Since 2005 he has been involved in research projects in the field of CMOS analog design, MOS transistor modeling and IoT applications for agribusiness.